

Clarke®

ENGINE REPAIR TABLE

Model No: CERT1225

Thank you for purchasing this Clarke Engine Repair table.

Please read this leaflet thoroughly in order to ensure it is assembled correctly, so that maximum benefit may be gained from its use, and to ensure it provides you with long and satisfactory service.

GUARANTEE

This product is guaranteed against faulty manufacture for a period of 12 months from the date of purchase. Please keep your receipt therefore, as proof of purchase.

This guarantee is invalid if the product is found to have been abused or tampered with in any way, or not used for the purpose for which it was intended.

Faulty goods should be returned to their place of purchase, no product can be returned to us without prior permission.

This guarantee does not effect your statutory rights.

Please note that the backing pad is not covered by this warranty.

SPECIFICATIONS

Load Capacity	136kg (300Lbs)
Overall Dimensions	1225x730x1050mm
Drawer Size	598x500x145mm
Drawer Load capacity	50kg (22lbs)
Oil Pan Capacity	16 litres
Net weight	75kg (187lbs)

ASSEMBLY

Carefully unpack the components and, with assistance due to its weight, invert the table top as shown in Fig.1, and place it on a sheet of cardboard or similar, to avoid damaging the paintwork.

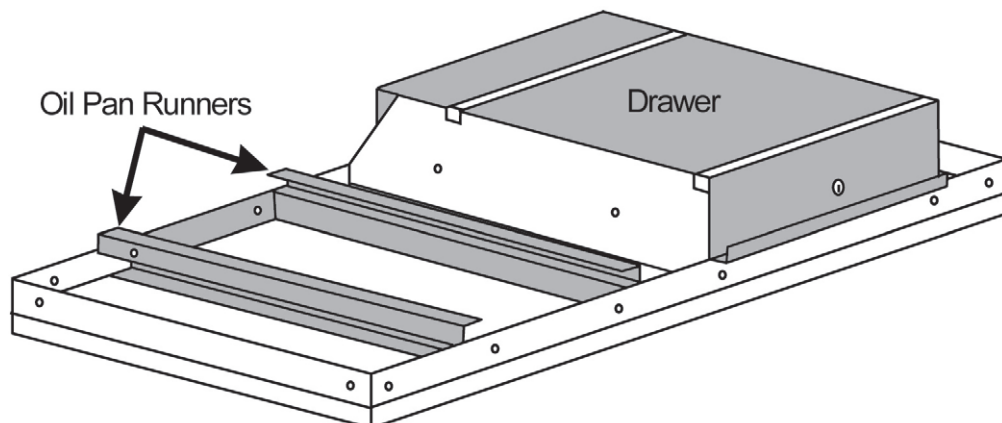

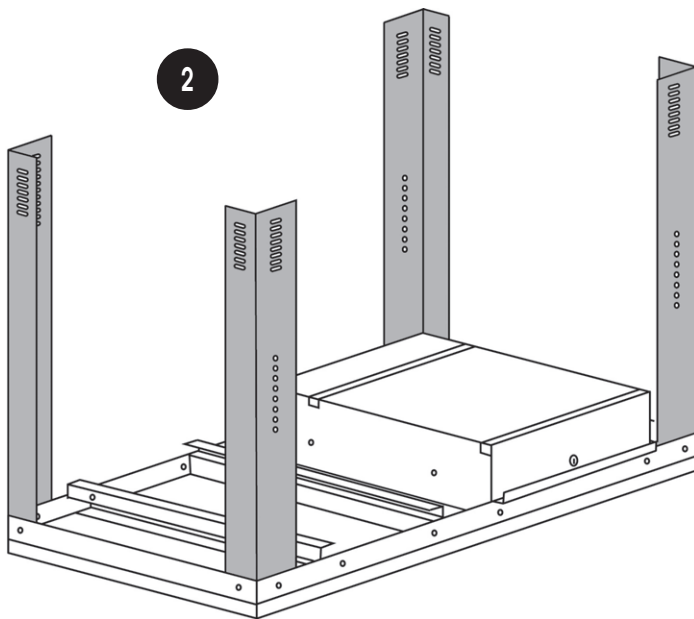

Attach the legs in the manner shown in Fig.2, using two M6 nuts bolts, lock washers and flat washers (supplied), per leg.

Do not fully tighten the nuts at this stage

Attach the shelf in the manner shown in Fig.3, using the M6 nuts bolts, lock washers and flat washers (supplied).

The shelf may be positioned, as desired.

Do not fully tighten the nuts at this stage

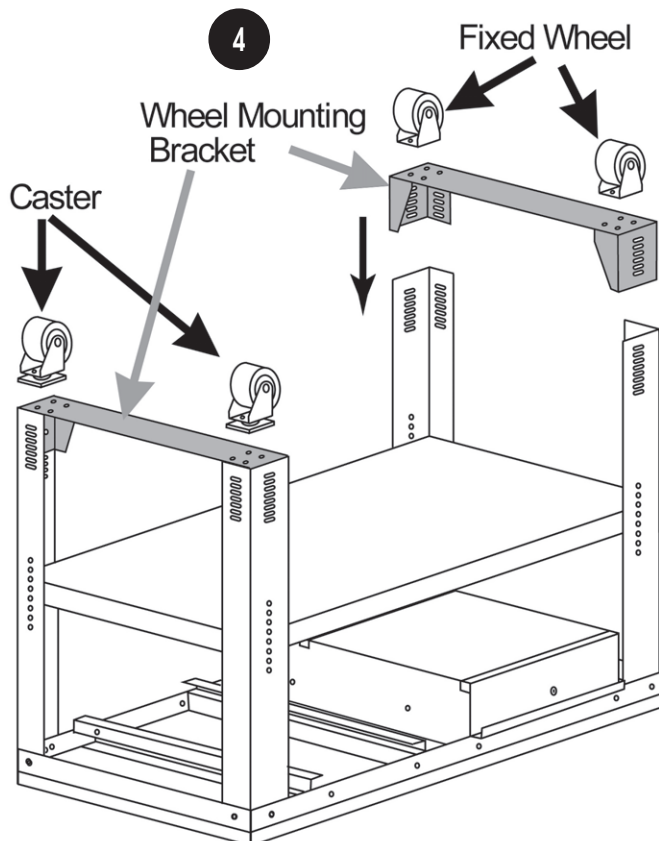
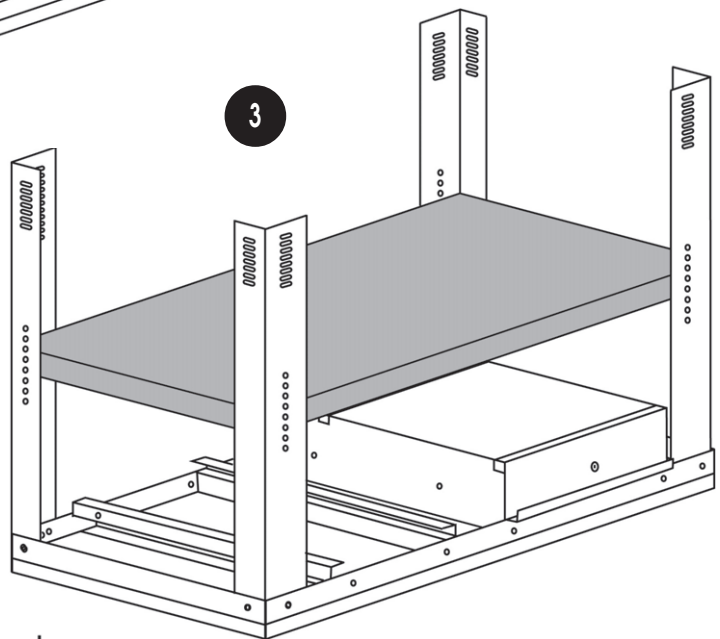

Attach the two wheel mounting brackets in the manner shown in Fig.4, using the M6 nuts bolts lock washers and flat washers supplied.

Bolt on the fixed wheels and casters, ensuring both casters are at the same end of the table, using the M8 nuts bolts and lock washers supplied, tightening the nuts fully. Finally, with assistance, turn the table so that it rests on it's wheels.

Rock the assembly gently to ensure it is completely stable, then proceed to fully tighten all nuts.

Slide the Oil Tray into place, on it's runners.

Your Engine Repair Table is now ready for use.

For safety, you should always ensure the casters are locked when the table is stationary.

Use on a firm level surface, and do not use on an incline.

**CAUTION: DO NOT OVERLOAD THE TABLE
MAX LOAD - 136KG (300LBS)**